



GOLDUNITED SDN BHD



HSRM Roller Shutter®



Auto/Manual Rolling Door and Window

Manufactured with advanced processing techniques, it replaces the traditional rolling door. It is the functional combination of decoration, prevention and protection. Advanced operation ways includes manual or remote controled with locking device.

Features

Fabricated from heat galvanized double layer steel plate or galvanized metal.

Suitable for door with large span.

The rails are made of aluminium that prevents rust.

Choice consists of manual, electrical or remote controlled motor.

Wireless remote and button on control box ensure door stays in exact position.

Special and yet modern design of features bring excellent vision effect, day lighting, ventilation and natural light into the building.

Multi-purpose and flexible to be used as decorative partitions, sidewalk separation with drive way and etc.

Provide anti-theft security to the properly owners.

All motors are equipped with interior overheat protection system.

Components

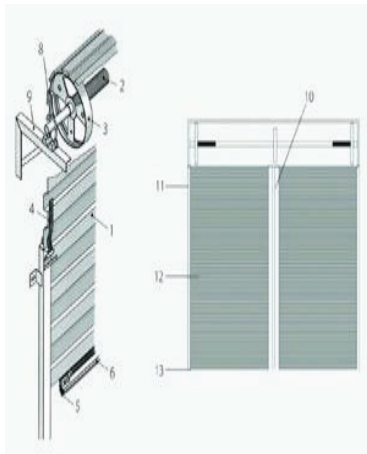

Auto/Manual Roller

1. Roller Door Curtain
2. Spring S with Bolt
3. Nylon Drum Wheel with Rivet
4. Polyglide
5. Full Width PVC Weather Seal
6. Aluminium Rail
7. Fixture Kits
8. Support Bracket
9. PVC Weather Seal
10. Aluminium Bar Center with Flush & Pedal
11. Aluminium Door Guard with Wall Plug
12. Door Lock with Flat Bar

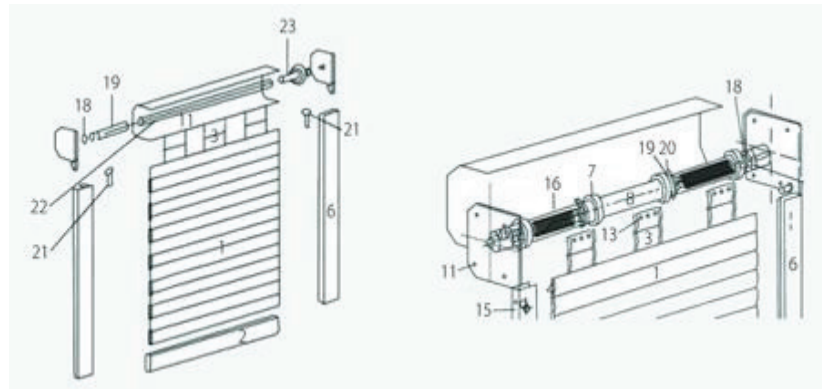

With Tubular Motor

1. Slat
2. Bottom Slat
3. Short Slat
4. PVC Side Clip
5. Expansion Screws
6. Guide Rail (SL 15)
7. PVC Ring
8. Steel Axle
9. Motor
10. Manual Crank (SL 151C)
11. Box23 Axle Insert
12. Nylon Guide Roller (SL 57)
13. Fixed Screw
14. Security Door Lock (SL 147)
15. Stop Mechanism
16. Tensional Spring (SL 154)

13. L or T Shape
Aluminium Bottom
Bar

17. Bracket

18. Bearing (SL 156)

19. Nut

20. Screw Bar

21. Guide Rail Inlet (SL 57)

22. Aluminium Axle (SL 101A)

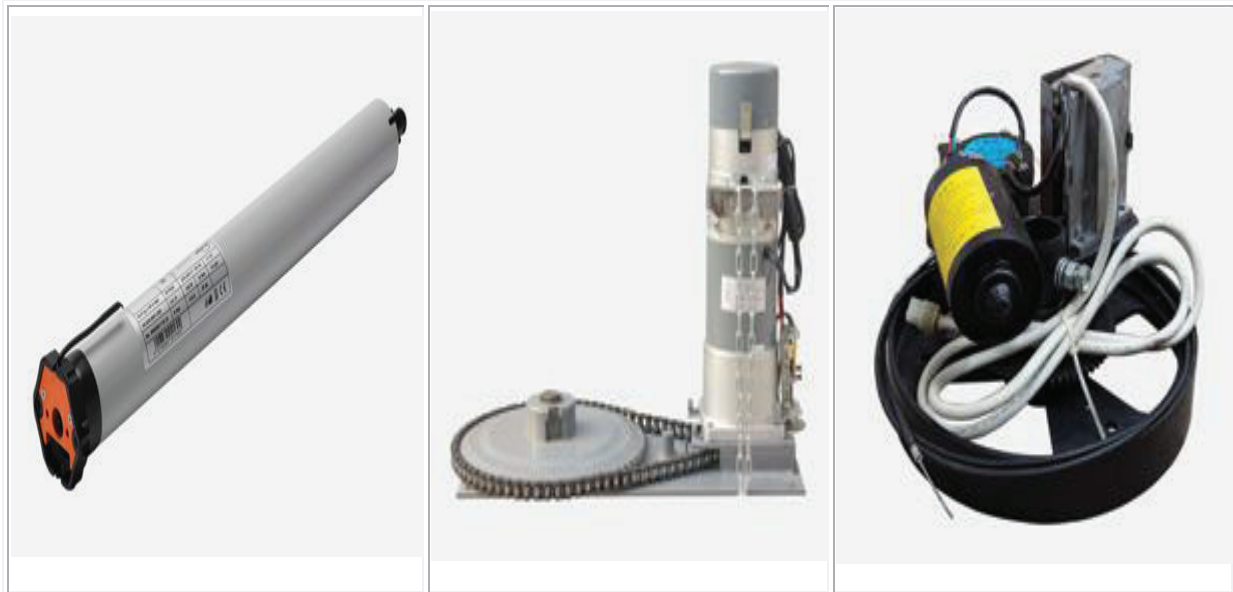

SL92-140M Tubular Motor	SLT 20 Tubular Motor	HS Gear Motor Fixed Externally	ET-16 & ET -22
Output Speed: 16rpm Output Torque: 15N.M Current: 1A Power: 180W Limit Revolution: 30	Output Speed: 12rpm Output Torque: 140N.M Current: 3.2A Power: 680W Limit Revolution: 16	Power: 150W Rating: 0.05m/s HS 300/250 Current: 1.67A	Power: 170-260V 50Hz Rating: 0.15-0.20m/s Remote Workable Distance:>50m

Time Rating: 4 min Tube Diameter: 45mm Complete Weight: 3.2kg Lift Weight: 22.5kg Length: 613mm Noise: <50db (A)	Time Rating: 4 min Tube Diameter: 92mm Complete Weight: 13.5kg Lift Weight: 210kg Length: 560mm Noise: <58db (A)	Tube Diameter: 100mm Noise: <60db(A)	Exterior Diameter: 260mm
---	--	---	-----------------------------